	<b>THABANA PIPESTORE CONSOLIDATED DETAILED DESIGN</b>	Doc. No	MES-MEC-REP-0146
		Page	1 of 20

Document Title	REPORT: THABANA PIPESTORE CONSOLIDATED DETAILED DESIGN
Number	MES-MEC-REP-0146
Revision	2.0

## APPROVAL & DISTRIBUTION

	NAME	SIGNED
Prepared	T Mudau Mechanical Engineer Mechanical Engineering Services	
Reviewed	OL Siko Mechanical Engineer Mechanical Engineering Services	
Reviewed	W Van Den Berg, Pr Eng (20060068) Chief Electrical Engineer Electrical Engineering	
Reviewed	A Kaisavelu Nuclear Safety Engineer L&SA	
Approved	SR Mngoma, Pr Eng (20110297) Acting Section Head Mechanical Engineering Services	
Accepted (Client)	L Hordijk Waste Specialist Waste Management	
Accepted	SM Mosinki Design Authority Chairperson	

	<b>THABANA PIPESTORE CONSOLIDATED DETAILED DESIGN</b>	Doc. No	MES-MEC-REP-0146
		Page	2 of 20

## DISTRIBUTION

\*(Electronic distribution only)

1	ENS Records	2	NLM Records
---	-------------	---	-------------

## REVISIONS

This document has been revised in accordance with the following schedule:

Rev. No	Date Approved	Nature of Revision	Prepared
1.0	2023/02/10	First Issue	WJ Jarvis
2.0	See title page	Change in Design Authority	T Mudau

	<b>THABANA PIPESTORE CONSOLIDATED DETAILED DESIGN</b>	Doc. No	MES-MEC-REP-0146
		Page	3 of 20

**TABLE OF CONTENTS**

APPROVAL & DISTRIBUTION ..... 1

1 DEFINITIONS AND ABBREVIATIONS ..... 4

2 REFERENCES ..... 5

3 PURPOSE ..... 7

4 SCOPE ..... 7

5 INTRODUCTION ..... 7

6 THABANA FACILITY DESCRIPTION ..... 10

7 SAFARI-1 STORAGE VESSEL DESIGN ..... 12

8 NTP U-RESIDUE MATERIAL STORAGE VESSELS DESIGN ..... 15

9 BUILDING EXTENSION AND AUXILIARY EQUIPMENT ..... 18

10 CONCLUSION ..... 20

**LIST OF FIGURES**

Figure 1: Schematic of the Thabana Pipestore (section view) ..... 9

Figure 2: Location of the Pipestore on Thabana Hill at the Necsa Pelindaba Site ..... 10

**LIST OF TABLES**

Table 1: Components with Material Changes of the Storage Pipe Assembly ..... 12

Table 2: Manufacturing Drawings for SAFARI-1 Storage Pipes ..... 13

Table 3: Components with Material Changes of the Storage Pipe Assembly ..... 15

Table 4: List of Manufacturing Drawings for the NTP Storage Pipes ..... 16

Table 5: List of Civil Works Drawings for the TPS ..... 19

Table 6: Electrical Drawings ..... 20

	<b>THABANA PIPESTORE CONSOLIDATED DETAILED DESIGN</b>	Doc. No	MES-MEC-REP-0146
		Page	4 of 20

## 1 DEFINITIONS AND ABBREVIATIONS

### 1.1 DEFINITIONS

Term	Definition
Thabana	Thabana refers to the area of Pelindaba site where nuclear waste is stored.
Thabana Pipestore	The Thabana Pipestore is a facility where nuclear waste is stored in lined boreholes. This facility is an interim storage

### 1.2 ABBREVIATIONS

Abbreviation	Definition
ASME	American Society of Mechanical Engineers
DPTE	Double Porte de Transfert Etanche (Double Port Transfer Exchange)
ECP	Engineering Change Proposal
FCCB	Facility Change Control Board
HCC	Hot Cell Complex
LTA	Lead Test Assemblies
LTS	Long Term Storage
NTP	Nuclear Technology Products
SAFARI-1	South African Fundamental Atomic Research Installation -1
SANS	South African National Standards
SSC	Structures, Systems and Components
TPS	Thabana Pipestore
UNF/SNF	Used Nuclear Fuel / Spent Nuclear Fuel
U-Residue	Uranium Residue

## 2 REFERENCES

Document Title / Drawing Title	Preparer / Author	Document Number	Revision / Date of Issue
[1] Thabana Pipestore (LCR A59)	De Kock JJJ – NLM	NL27/NW-PSA-0012	1997
[2] Pipestore Facility Design	Maphisa E		2004
[3] Report: Thabana Pipestore Consolidated Basic Design	OL SIKO	MES-MEC-REP-0132	3.0
[4] NUCLEAR INSTALLATION LICENCE NIL-04: NIL04-NAR-0019: THABANA PIPESTORE EXPANSION PROJECT – BASIC DESIGN REPORT – RESPONSE TO NIL04B0166	T Pather	NIL04B0173	N/A
[5] Thabana Pipestore User Requirements for SAFARI-1 Spent Fuel and Control Rod Assemblies	TS MAAGE – SAFARI-1	RR-SPE-0041(CMS 134918)	Rev 01
[6] User Requirements Statement: Long Term Storage of Uranium Residue	Mahlong R – NTP	NTP-SPE-4105	Rev 2
[7] SSC Classification of The Thabana Pipestore Extension	BL Cawood	LSA-NLM2018-REP-0002	4
[8] Thabana Pipestore Design Control Plan	T Nzo	PCS-PROJ-PLN-0001	1
[9] SHEQ Approval of Projects	SHEQ Department	SHEQ-INS-0800	5
[10] NLM change proposal request and design change control package	L Hordijk	NLM-CHR-20/003	n/a
[11] Thabana Pipestore Design Specification	OL Siko	MES-MEC-SPE-0018	1
[12] Thabana Storage Pipe Design for NTP (Basic design Report)	T Mudau	MES-MEC-REP-0124	3
[13] Thabana Storage Pipe Design for SAFARI-1 (Basic design Report)	T Mudau	MES-MEC-REP-0125	3

[14]	Facility and Process Description of the Extended Thabana Pipestore	JH Lubbinge	NLM-PD-00029	4.0
[15]	System Breakdown structure for the 2020 TPS extension	L Hordijk	NLM-PLN-00405	00
[16]	HSE basis of design and design requirements for Thabana Pipestore extension	T Nzo	PSC-PROJ-RQM-0001	1
[17]	Thabana Storage Vessel Design for SAFARI-1 (Detailed Design Report)	T Mudau	MES-MEC-REP-0144	1.0
[18]	Thabana Pipestore: Updates to the NTP and SAFARI-1 Drawings for Thabana Pipestore	T Mudau	MES-MEC-ECP-0004	1.0
[19]	Thabana Storage Vessel Design for NTP (Detailed Design Report)	T Mudau	MES-MEC-REP-0143	1.0
[20]	Design Report: Detail Design Thabana Pipestore Portal Frame and Foundation	W Jarvis	MES-CIV-REP-0037	1.0
[21]	Thabana Extension to Pipestore Facility: Site Layout	W Jarvis	MES-CIV-ECP-0001	1.0
[22]	Design Report: Thabana Pipestore Portal Frame and Foundation	W Jarvis	MES-CIV-REP-0029	1.0
[23]	Thabana Extension to Pipestore Facility: NTP Extension Steelwork	W Jarvis	MES-CIV-ECP-0005	1.0
[24]	Thabana Extension to Pipestore Facility: SAFARI-1 Extension Steelwork	W Jarvis	MES-CIV-ECP-0006	1.0
[25]	Thabana Extension to Pipestore Facility: General Arrangement	W Jarvis	MES-CIV-ECP-0002	1.0
[26]	Dose-Rate Assessment for the Thabana Pipe-Store Holding Irradiated SAFARI-1 LEU Fuel-Assemblies	TJ van Rooyen	RRT-SHLD-REP-18003	01
[27]	Thabana Extension to Pipestore Facility: NTP Extension Concrete	W Jarvis	MES-CIV-ECP-0003	1.0
[28]	Thabana Extension to Pipestore Facility: SAFARI-1 Extension Concrete	W Jarvis	MES-CIV-ECP-0004	1.0

	<b>THABANA PIPESTORE CONSOLIDATED DETAILED DESIGN</b>	Doc. No	MES-MEC-REP-0146
		Page	7 of 20

[29] Thabana Pipestore Crane Assessment	U Suliman	JN877-NSE- NEC-R-8932	0
---	-----------	--------------------------	---

### 3 PURPOSE

This document is a consolidated detailed design report that provides a background of the project and applicable documents pertaining to the existing Thabana Pipestore (TPS), the change request for the new extension, the detailed design of the TPS extension relative to the existing TPS facility for storage of Spent Nuclear Fuel (SNF) from SAFARI-1 and Uranium-Residue (U-Residue) from NTP.

### 4 SCOPE

The scope of this document covers the following:

- Thabana Facility Description;
- SAFARI-1 Storage Pipe Design;
- NTP U-Residue Material Storage Pipe Design; and
- Building Extension and Auxiliary Equipment.

### 5 INTRODUCTION

The TPS is currently being used as an interim storage facility for SNF from the SAFARI-1 research reactor. This interim storage facility was licensed under [1] in 1997 and the facility was extended in 2007. It is intended to use the TPS for the storage of U-Residue material from the NTP Hot Cell Complex (HCC). The extended TPS facility will be divided into two sections; one to store the spent fuel from SAFARI-1 research reactor, and a second section to store the U-Residue material from NTP HCC.

According to [2] storage pipes were also initially installed at the TPS for HCC waste related to Lead Test Assemblies (LTA). A total of 56 pipes were encased in concrete at a depth of 7 m but were never used. The existing HCC storage pipes will be left intact and not utilized because they are open to the atmosphere. The diameter is inadequate and would require significant modification to allow for the storage of the U-Residue containers. Furthermore, the projected quantity of NTP U-Residue to be stored would require many more storage pipes than was currently available.

	<b>THABANA PIPESTORE CONSOLIDATED DETAILED DESIGN</b>	Doc. No	MES-MEC-REP-0146
		Page	8 of 20

Therefore, 36 new storage pipes are required for the NTP U-Residue material at a maximum depth of 16.73 m and 48 pipes are required for the SNF from SAFARI-1 at 16.73 m depth (see Refs. [5] and [6]). Figure 1 shows a schematic of the TPS facility.

The basic design has been completed and is presented in MES-MEC-REP-0132 [3], which was approved by the NNR in Letter NIL04B0173 [4]. The detailed design presented in this document will expand on the basic design. This involves looking at manufacturability, constructability and availability of materials. Aspects which have been presented in the basic design will not be repeated in this report. This report will highlight the changes made from basic to detailed design.

This report is divided into four chapters. The Thabana Facility Description is presented in Section 6. The SAFARI-1 Storage Pipe Design is presented in Section 7. The NTP U-Residue Material Storage Pipe Design is presented in Section 8. Building Design and Auxiliary Equipment are presented in Section 9. Additional schematics of the existing TPS are presented in the Appendix section of this document. Different engineering disciplines were involved in the different sections of TPS facility design, as a result many reports were prepared for each respective section. Each of the reports followed the procedure outlined in the design control plan for the TPS facility (PCS-PROJ-PLN-0001 [8]). The findings from these reports are summarized and consolidated in this document.

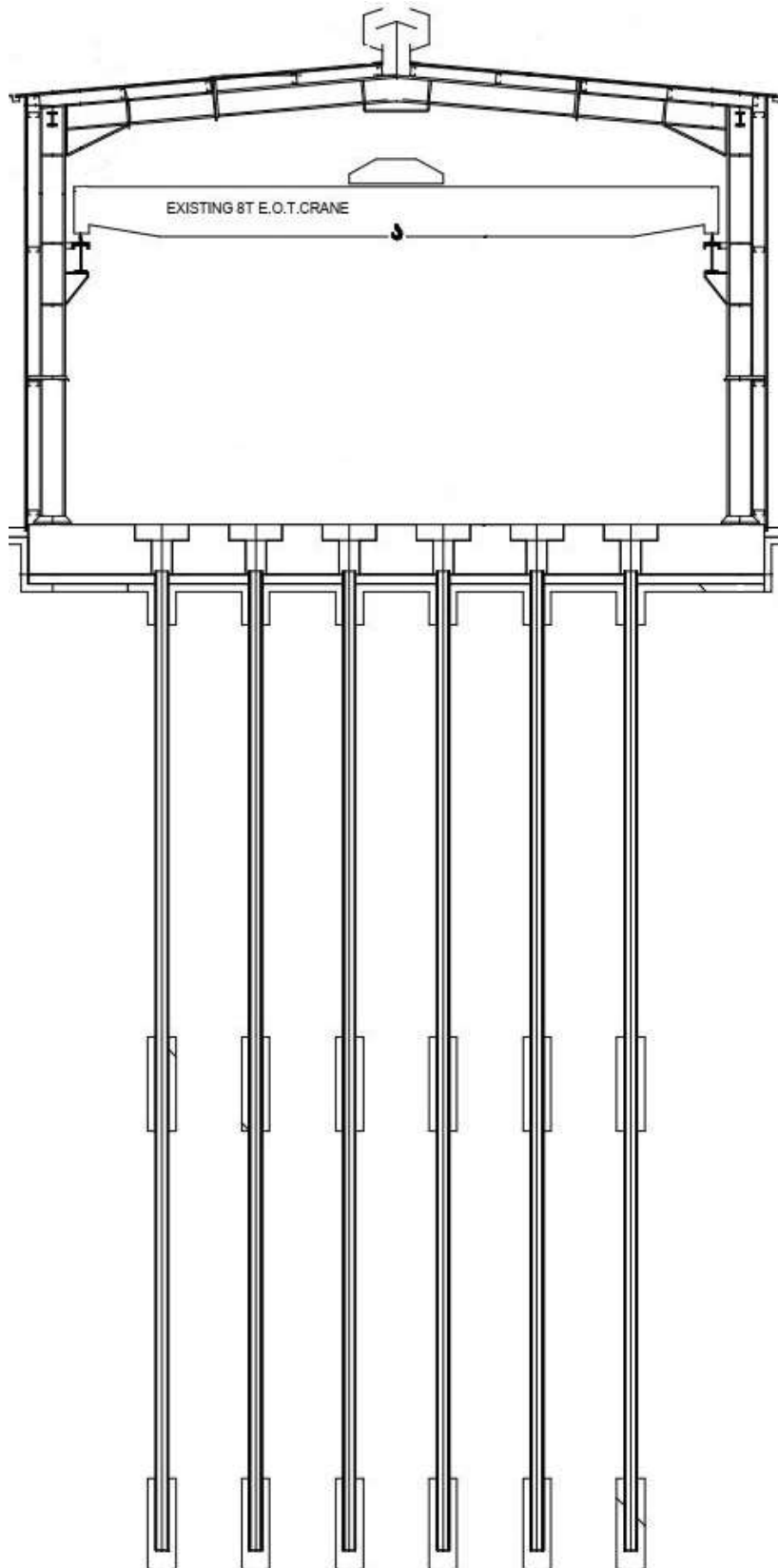

**Figure 1: Schematic of the Thabana Pipestore (section view).**

## 6 THABANA FACILITY DESCRIPTION

### 6.1 CURRENT TPS FACILITY

#### 6.1.1 Facility description

The current facility is described in the following sections. This information for the current TPS facility is detailed in the document listed in the table below:

Document Title	Author	Document Number	Rev. No.
Pipe Store Facility design	E Maphisa	NW-PDD-0001 [2]	00

#### 6.1.2 Site map of facility

The TPS is located in the Thabana area of the Pelindaba site (Figure 2). The extension to the facility is planned for the southern and northern sides of the current TPS, adjacent to the existing SAFARI-1 SNF storage pipes and HCC storage pipes. The proposed new layout is detailed in the Site Layout Drawing NNDD-Thabana-A-LG-0001.



**Figure 2: Location of the Pipestore on Thabana Hill at the Necsa Pelindaba Site.**

	<b>THABANA PIPESTORE CONSOLIDATED DETAILED DESIGN</b>	Doc. No	MES-MEC-REP-0146
		Page	11 of 20

## 6.2 EXTENDED FACILITY

### 6.2.1 User Requirements Specification

The user requirements for the SAFARI-1 SNF are listed in [5]. The user requirements for the NTP U-Residue material are listed in [6].

### 6.2.2 Facility change management

The NLM internal process (in accordance with the applicable requirements in SHEQ-INS-0236) was followed to approve and introduce the required change at the TPS. The change request was to extend the TPS to make provision for the storage of additional SAFARI-1 spent fuel, and introduce storage capacity for the U-Residue material from NTP. The change was reviewed and approved by the NLM FCCB [10].

### 6.2.3 Facility and Process Description

The details for the extension of the current TPS facility are detailed in the document listed in the table below:

Document Title	Author	Document Number	Rev. No.
Facility and Process Description of the Extended Thabana Pipestore	JH Lubbinge	NLM-PD-00029 [14]	4.0

### 6.2.4 Other documents

The following assessments and documents prepared related to the extended Pipestore:

Document Title	Author	Document Number	Rev. No.
SSC classification for the Thabana Pipestore extension	L Cawood	LSA-NLM2018-REP-0002 [7]	4.0
System Breakdown structure for the 2020 TPS extension	L Hordijk	NLM-PLN-00405[15]	00
HSE basis of design and design requirements for Thabana Pipestore extension	T Nzo	PSC-PROJ-RQM-0001 [16]	1

	<b>THABANA PIPESTORE CONSOLIDATED DETAILED DESIGN</b>	Doc. No	MES-MEC-REP-0146
		Page	12 of 20

## 7 SAFARI-1 STORAGE VESSEL DESIGN

The SAFARI-1 storage pipes section in the TPS facility are used for the storage of SNF from the SAFARI-1 research reactor. The SNF elements are first placed inside storage baskets and then the storage baskets are stored inside the storage pipes at the TPS facility. There are currently 60 storage pipes in the TPS used for this purpose.

### 7.1 DESIGN CHANGES OF THE SAFARI-1 STORAGE VESSEL ASSEMBLY

The TPS facility currently consists of SAFARI-1 storage pipes and it is intended to increase the number of storage pipes available for storage purposes. The design requirements and design calculations of the SAFARI-1 storage pipes are presented in the basic design report [3]. The detailed design process has led to the alteration of the material of construction. This alteration is due the availability and clarity on the material originally specified. This material change is noted and controlled in MES-MEC-REP-0144 [17] and MES-MEC-ECP-0004 [18] respectively. Table 1 shows the components that this material change has affected. As the mechanical properties of the materials do not change, no analysis is required as confirmed in MES-MEC-ECP-0004 [18].

**Table 1: Components with Material Changes of the Storage Pipe Assembly**

Component/ Part	Description of Change
1. Shuttering	The material specification has changed from EN 10052 S355J to EN10052 S355JR to improve clarity.
2. Pipe Plug	The complete name including product form of the material is now specified for the following components of the pipe plug. The plates are ASTM A 240 Gr.304L. The coil is ASTM A 276 Gr.304L. The insert is ASTM A 479 Gr.304L.
3. Anti-tamper Seal	The complete name including product form of the material is now specified as ASTM A 240 Gr.304L.
4. Cover	The material was originally specified as carbon steel. The material is now specified as EN10025 S355JR for improved clarity.
5. Locating Ring	The complete name including product form of the material is now specified as ASTM A 240 Gr.304L.

Component/ Part	Description of Change
6. Vacuum Flange	The complete name including product form of the material is now specified as ASTM A 182 Gr.304L

### 7.1.1 Manufacturing Drawings

The drawings presented in Table 2 shall be used to manufacture the SAFARI-1 storage pipes.

**Table 2: Manufacturing Drawings for SAFARI-1 Storage Pipes.**

Drawing Number	Drawing Title	Revision
APO-017-0207-101-011218	Thabana Pipestore (SAFARI-1)	1.0
APO-0170207-101-011222	Borehole Casing	1.0
APO-0170207-101-011220	Shuttering	1.0
APO-0170207-101-011223	Fibre Cement Assembly	1.0
APO-0170207-101-011232	Fibre Cement Pipe	1.0
APO-0170207-101-011227	Lead shield	1.0
APO-0170207-101-011219	Storage Vessel	2.0
APO-0170207-101-011229	Spring	1.0
APO-017-0207-103-011224	Pipe Plug	2.0
APO-0170207-101-011226	Flange	1.0
APO-0170207-101-011225	Anti-Temper Cover	2.0
APO-0170207-101-011230	Seal Screw	1.0

<b>Drawing Number</b>	<b>Drawing Title</b>	<b>Revision</b>
APO-0170207-101-011228	Cover	2.0
APO-0170207-101-011220	Pedestal	2.0
74M724-01-00	Valve and Fitting Assembly	1.0
APO-0170207-101-011231	Cone	2.0

### 7.1.2 Conclusion

All calculated stresses fall within the allowable code limits. The structural integrity of the Thabana storage vessel for SAFARI-1 therefore complies with the rules of ASME Section III division 1 Subsection ND and NF. It is therefore concluded that the storage pipe should be manufactured according to the design presented in [11] & [13] and the manufacturing drawings listed (Table 2). This design meets technical requirements [5] & [11] and SHEQ-INS requirements [9].

	<b>THABANA PIPESTORE CONSOLIDATED DETAILED DESIGN</b>	Doc. No	MES-MEC-REP-0146
		Page	15 of 20

## 8 NTP U-RESIDUE MATERIAL STORAGE VESSELS DESIGN

The NTP storage pipes section in the TPS facility is used for the storage of U-Residue material from HCC. The U-Residue is placed inside 2L containers, and the 2L containers are placed/stored inside the 174 DPTE container. The 174 DPTE container is then placed inside the LTS canister, and the LTS canisters are stored inside the storage pipes in the TPS facility.

### 8.1 DESIGN CHANGES OF THE NTP STORAGE VESSELS

The NTP storage pipes to be constructed at the TPS facility will have the same components/parts as the existing/manufactured SAFARI-1 storage pipes (see Table 1). The only difference is that the dimensions (internal diameters of the pipes will be larger in order to accommodate the outer diameter of the LTS container. The design requirements and design calculations of the NTP storage pipes is presented in the basic design report [3]. The detailed design process has led to the alteration of the material of construction. This alteration is due the availability and clarity on the material originally specified. This material change is noted and controlled in MES-MEC-REP-0143 [20] and MES-MEC-ECP-0004 [18] respectively. Table 1 shows the components that this material change has affected. As the mechanical properties of the materials do not change, no analysis is required as confirmed in MES-MEC-ECP-0004 [18].

**Table 3: Components with Material Changes of the Storage Pipe Assembly**

Component/Part	Description of Change
1. Shuttering	The material specification has changed from EN 10052 S355J to EN10052 S355JR to improve clarity.
2. Pipe Plug	The complete name including product form of the material is now specified for the following components of the pipe plug. The plates are ASTM A 240 Gr.304L. The coil is ASTM A 276 Gr.304L. The insert is ASTM A 479 Gr.304L.
3. Anti-tamper Seal	The complete name including product form of the material is now specified as ASTM A 240 Gr.304L.
4. Cover	The material was originally specified as carbon steel. The material is now specified as EN10025 S355JR for improved clarity.

Component/Part	Description of Change
5. Locating Ring	The complete name including product form of the material is now specified as ASTM A 240 Gr.304L.
6. Vacuum Flange	The complete name including product form of the material is now specified as ASTM A 182 Gr.304L.

### 8.1.1 Manufacturing Drawings

The table below (Table 4) shows a list of output drawings (manufacturing drawings).

**Table 4: List of Manufacturing Drawings for the NTP Storage Pipes.**

Drawing Number	Drawing Title	Revision
APO-017-0206-101-011165	Thabana Pipestore (NTP)	2.0
APO-017-0206-103-011166	Storage Vessel	3.0
APO-017-0206-103-011167	Shuttering	3.0
APO-017-0206-103-011168	Pedestal	3.0
APO-017-0206-103-011169	Borehole Casing	1.0
APO-017-0206-103-011170	Fibre Cement Assy	2.0
APO-017-0206-103-011171	Plug	2.0
APO-017-0206-102-011172	Anti-Tamper Cover	3.0
APO-017-0206-102-011173	Flange	2.0
APO-017-0206-102-011174	Lead Shield	3.0
APO-017-0206-102-011175	Cover	1.0
APO-017-0206-102-011176	Spring	1.0
74M724-01-00	Valve and Fitting Assy	1.0
M10 ISO 7089 M 10 STEEL	Flat Washer	1.0
M10 ISO 4032 STEEL 8	Hexagon Nut	1.0
M24 x 100 ISO 4014 STEEL 8.8	Hex Cap Screw (Partially Threaded)	1.0
M 24 ISO 7089 STEEL	Flat Washer	1.0
M24 ISO 4032 STEEL 8	Hex Nut	1.0
M12 DIN 580 STEEL C15	Lifting Eye Bolt	1.0
M8 CHEMSET	Masonry Anchor	1.0

	<b>THABANA PIPESTORE CONSOLIDATED DETAILED DESIGN</b>	Doc. No	MES-MEC-REP-0146
		Page	17 of 20

Drawing Number	Drawing Title	Revision
M10 x 30 ISO 4017 STEEL 8.8	Hex Cap Screw (Fully Threaded)	1.0
H5214-00-00	17 L Storage Container	1.0

### 8.1.2 Conclusion

All calculated stresses for the storage vessel fall within the allowable Code limits. The structural integrity of the Thabana storage vessel for NTP therefore complies with the rules of ASME Section III division 1 Subsection ND and NF. This design meets technical requirements [6] & [11] and SHEQ-INS requirements ([9]). It is therefore concluded that the storage pipe should be manufactured according to the design presented in [11] & [12] and the manufacturing drawings listed (Table 4).

	<b>THABANA PIPESTORE CONSOLIDATED DETAILED DESIGN</b>	Doc. No	MES-MEC-REP-0146
		Page	18 of 20

## **9 BUILDING EXTENSION AND AUXILIARY EQUIPMENT**

### **9.1 THABANA PIPESTORE BUILDING**

#### **9.1.1 Function of the building**

The primary function of the TPS building is to provide shelter for the storage pipes and other equipment. It protects the TPS from rainwater, dust, and heat from sunlight. Access into the building is controlled by a lockout procedure designed to prevent unauthorized entry into the store.

### **9.2 DESIGN CHANGES OF THE STRUCTURE**

During the process of completing the detailed design, there were 6 design changes from the NNR approved basic design [4] which are illustrated in MES-CIV-REP-0037 [20]. These changes are discussed in the following sections.

#### **9.2.1 General Layout**

The fence was extended to the southern side by approximately 11 m to accommodate the earthworks required to construct the southern side extension. This is reflected in MES-CIV-ECP-0001 [21].

#### **9.2.2 Portal Frame**

The sizing of the all structural members and connections was performed in MES-CIV-REP-0029 [22].

The manufacturing drawings for each individual item described in the Assembly Drawing NNDD-THABANA-C-FR-0001 for the NTP side extension and the Assembly Drawing NNDD-THABANA-C-FR-0002 for the SAFARI-1 side extension was produced. Other changes to the two assembly drawings include the number of bolts and their lengths. These changes are reflected in MES-CIV-ECP-0005 [23] and MES-CIV-ECP-0006 [24] for the NTP and SAFARI-1 side respectively.

##### **9.2.2.1 Cladding**

The sheeting chosen during the basic design was a 0.6 mm IBR sheeting. This was chosen as it is what is currently being used at Thabana.

While checking the detailed design for constructability, it was discovered that 0.6 mm IBR sheeting is no longer in production and has been replaced by 0.58 mm IBR sheeting.

	<b>THABANA PIPESTORE CONSOLIDATED DETAILED DESIGN</b>	Doc. No	MES-MEC-REP-0146
		Page	19 of 20

The allowable spans of both the walls and roof was checked against the specifications of 0.58 mm IBR sheeting and the design was found to be compliant.

This change is reflected in the Engineering Change Proposal MES-CIV-ECP-0002 [25].

### 9.2.3 Concrete Works

The concrete works drawing was updated in two ways. The first was to distinguish between the high-density magnetite concrete (as specified by RRT-SHLD-REP-18003 [26]) and the normal concrete. The second was to alter the bending schedule to reflect the updated bending codes as specified in the latest version of SANS 282. These changes are captured in the MES-CIV-ECP-0003[27] for the NTP side. The changes are captured in MES-CIV-ECP-0004[28] for SAFARI-1 side.

### 9.2.4 Earthworks

The earthworks drawings are prepared to assist in construction. These drawings are NNDD-THABANA-C-CONC-0005 and NNDD-THABANA-C-CONC-0006.

The earthworks drawings dictate new working levels, compaction requirements and bank slopes.

The earthworks shall be performed in accordance with the SANS 1200 series.

### 9.2.5 Crane Extension

The existing crane was independently assessed for compliance. The report [29] found the crane to be correctly designed with the exception on the crane end stops, where not enough information was available to make a definitive conclusion. As such, it was recommended that limit switches be placed on the new end stops to prevent any collision. This recommendation will be followed during the installation of the extension.

## 9.3 DRAWING LIST

The table below (Table 5) shows a list of detailed design drawings (manufacturing drawings).

**Table 5: List of Civil Works Drawings for the TPS .**

Drawing Number	Drawing Title	Revision
NNDD-THABANA-A-LG-0001	Site Layout	2.0

Drawing Number	Drawing Title	Revision
NNDD-THABANA-A-LG-0002	General Arrangement	2.0
NNDD-THABANA-C-CONC-0001	NTP Extension Concrete	2.0
NNDD-THABANA-C-CONC-0002	SAFARI-1 Extension Concrete	2.0
NNDD-THABANA-C-CONC-0005	Preparatory Earthworks	1.0
NNDD-THABANA-C-CONC-0006	Final Skirting Slab and Drainage	1.0
NNDD-THABANA-C-FR-0001	NTP Extension Steelwork	2.0
NNDD-THABANA-C-FR-0002	SAFARI-1 Extension Steelwork	2.0

## 9.4 AUXILIARY EQUIPMENT

### 9.4.1 Power supply

The electrical design has not changed since the basic design and the drawings in Table 6 still apply.

**Table 6: Electrical Drawings.**

Drawing Number	Drawing Title	Revision
74E120 (SHT 2)	Site Lighting Layout	3.0
74E113 (SHT 2)	Small Power / Single Phase Power Layout	4.0
74E112 (SHT 2)	Lighting Layout	4.0
74E330 (SHT 1)	Cable Schedule	8.0
74E331 (SHT 1/4)	Cable Schedule	4.0
74E331 (SHT 2/4)	Cable Schedule	7.0
74E331 (SHT 3/4)	Cable Schedule	7.0
74E331 (SHT 4/4)	Cable Schedule	7.0
74E121 (SHT 1)	Single Line Diagram	13.0
74E121 (SHT 2)	Single Line Diagram	3.0

## 10 CONCLUSION

The detailed design of the mechanical, civil and electrical engineering for the Thabana Pipestore is complete and the project is ready to move onto manufacturing and construction.